

FocusTest™ Series

Polarization Test System



Features

- High repeatability of test
- Stable and reliable
- Simple and convenient operation
- Compact size
- Flexible customization

Applications

- Identification of polarization states
- Testing of polarization degree
- Applicable to single emitters or single bars packaged

Product Dimensions (mm)

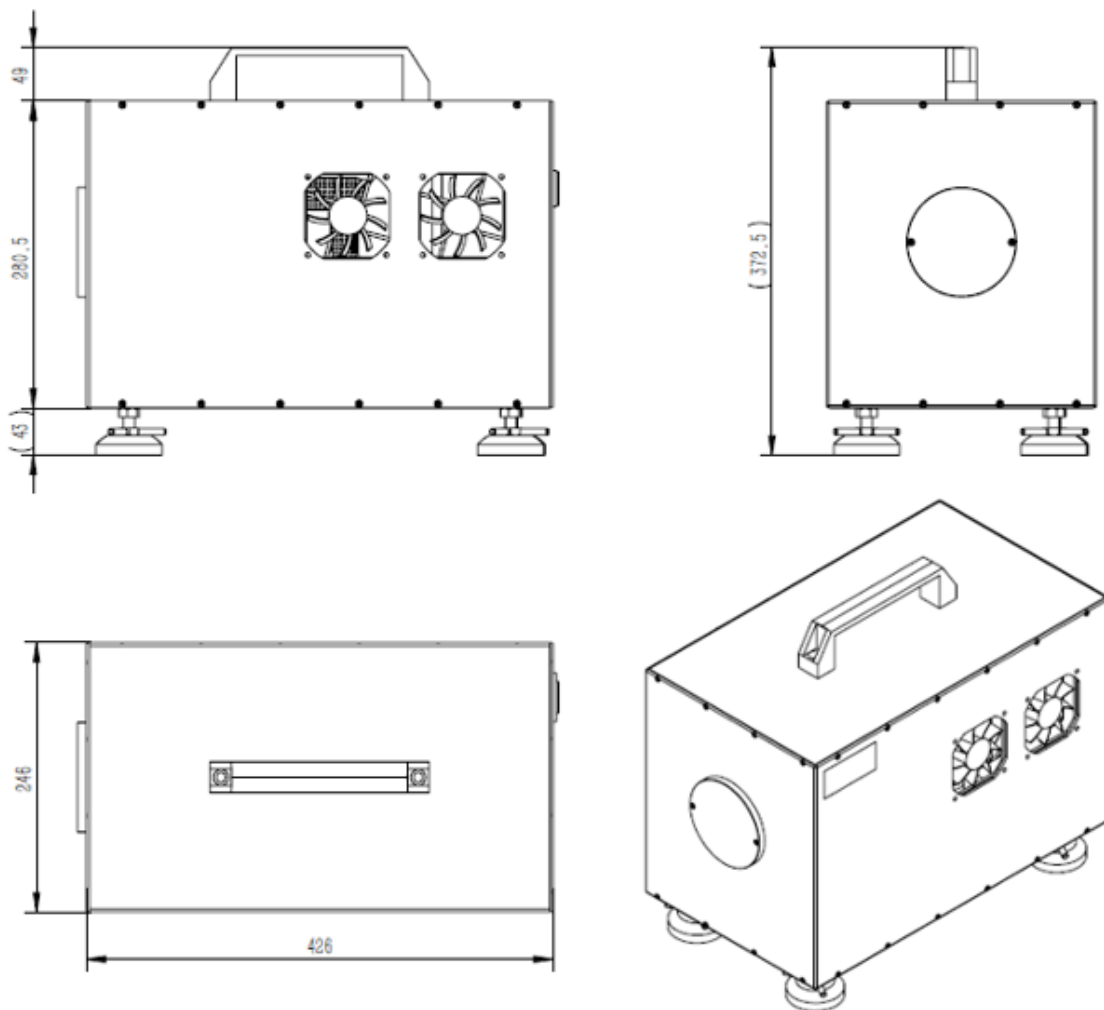

Remark: The structure drawing is for reference only. Please feel free to contact us for any special requirements.

Product Specifications

Product Code

Part No. FL-POL-100

General Data	Unit	Value
Dimensions (Width x Depth x Height)	mm	430 x 250 x 370
Weight	kg	< 20

Testing Capabilities

Polarization Test Accuracy	%	±1
Power	W	≤ 100
Wavelength Range	nm	600 ~ 1000
Testing Power Source (CW)	A	≤ 150

Temperature Control (Optional)

Range	°C	15 ~ 80
Accuracy	°C	± 0.2

Chiller (Optional)

Range	°C	15 ~ 30
Cooling Water Pressure	bar	3.5
Accuracy	°C	± 1

Computer and Software

Computer	IPC
System Software Functions	Control power source, automatic testing; Automatically generate profiles and reports

Communication Interface

Computer Interface	USB2.0 RS232
--------------------	--------------

Electric Parameter

Power Supply	AC 220V / 50Hz
--------------	----------------

